

Screw jacks

Contents

3.7	HSE range dimension plans	89-98
3.7.1	Type 1	90-94
3.7.1.1	Standard	90-91
3.7.1.2	With added-on limit switches Sm/Si	92
3.7.1.3	Anti-turn device Vm/Vi with added-on limit switches	92
3.7.1.4	With short safety nut	92-93
3.7.1.5	With long safety nut (BGV C1 or VBG 14)	93
3.7.1.6	Swivelling configuration	94
3.7.1.7	Swivelling configuration with added-on limit switches	94
3.7.2	Type 2	96-98
3.7.2.1	Standard	96-97
3.7.2.2	With short safety nut	97
3.7.2.3	With long safety nut (BGV C1 or VBG 14)	98
3.7.2.4	In HLA configuration	98

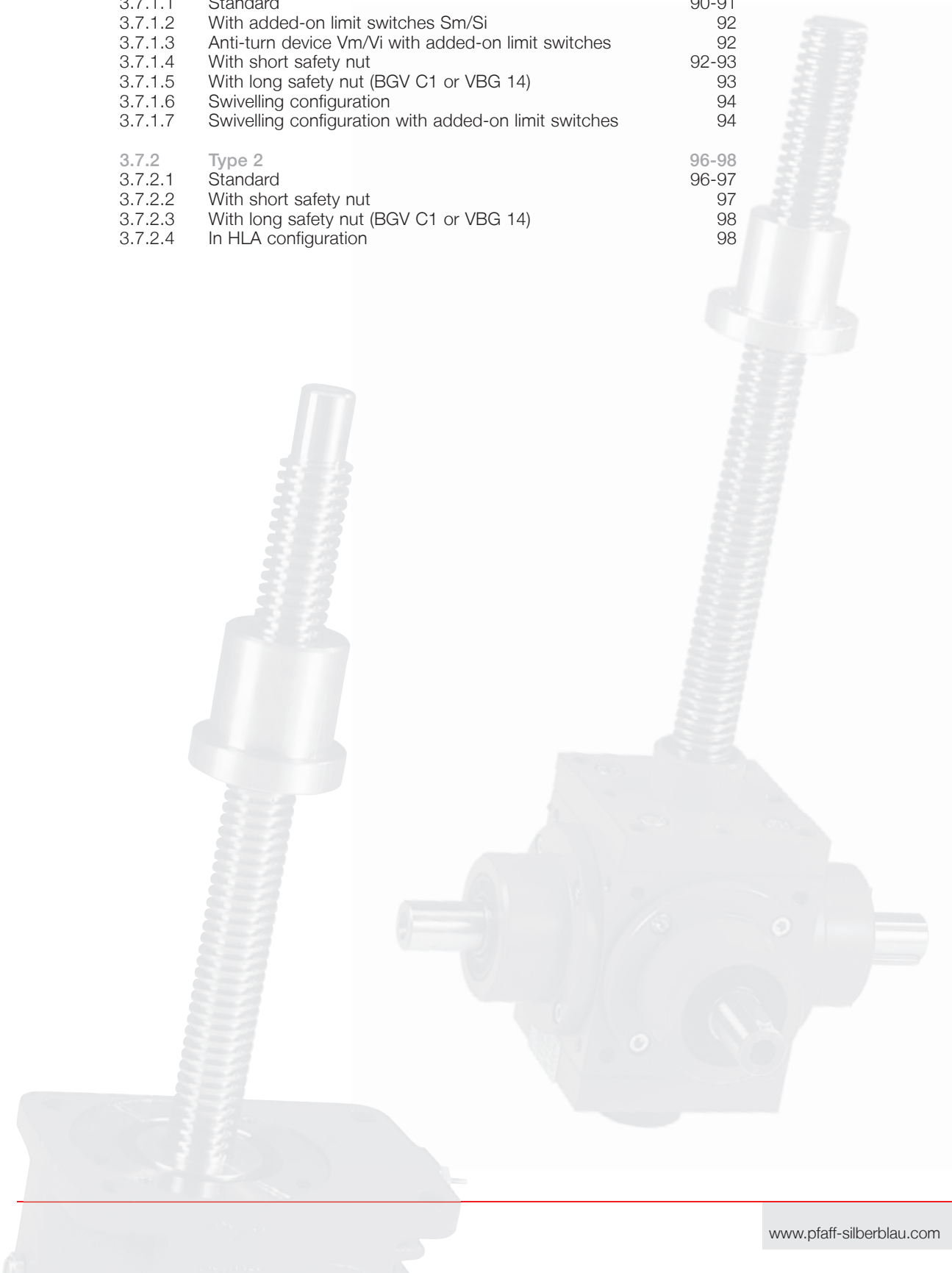

3.7 HSE range dimension plans

3.7.1 Type 1

3.7.1.1 Standard

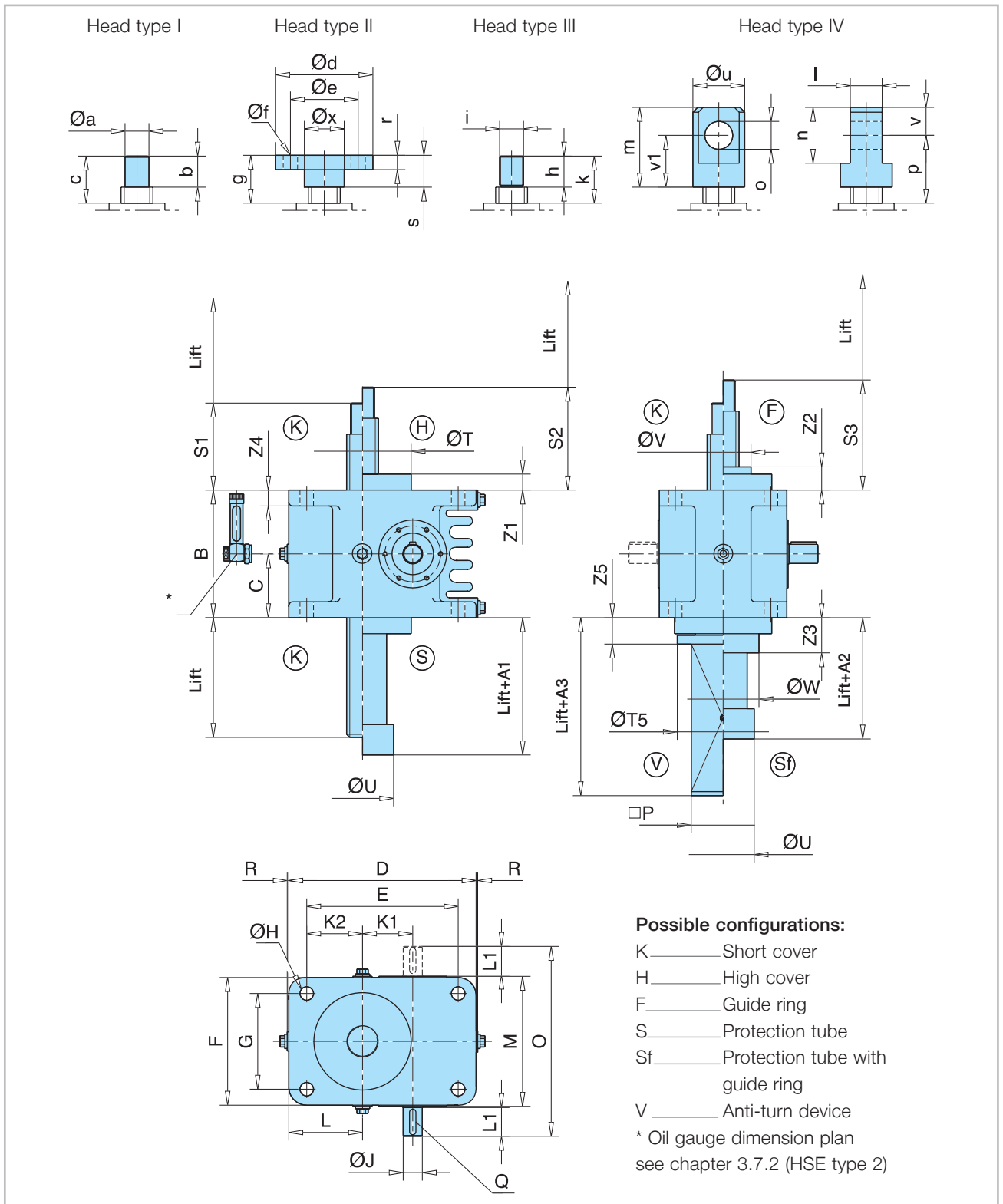

Screw jacks

Size	32 ²⁾	36.1 ¹⁾	50.1 ¹⁾	63.1 ¹⁾	80.1 ¹⁾	100.1 ¹⁾	125.1 ¹⁾	140	200.1 ¹⁾
Screw	Tr 18x6	Tr 24x5	Tr 40x8	Tr 50x9	Tr 60x12	Tr 70x12	Tr100x16	Tr 120x16	Tr 160x20
A 1	22	22	22	22	22	23	22	22	22
A 2	39	44	46	52	61	71	76	86	101
A 3	98	104	117	123	136	146	154	179	199
B	80	105	130	160	200	230	300	350	450
C	40	52,5	65	80	100	115	150	175	225
D	117	138	175	235	275	330	410	490	680
E	95	110	140	190	220	270	330	390	550
F	80	105	130	160	200	230	300	350	460
G	62	80	100	120	150	175	230	260	330
Ø H	9	9	13	17	21	28	39	46	66
Ø J k6	14	14	16	24	32	38	42	50	70
K 1	32	36	50	63	80	100	125	140	196
K 2	31	40	50	70	75	87,5	110	130	185
L	42	54	67,5	92,5	102,5	117,5	150	180	250
L 1	25,5	18	28	36	58	58	82	82	105
M	83	108	133	163	204	235	305	355	470
N	86	112	136	166	206	240	310	360	472
O	140	140	192	238	322	356	474	524	682
□ P	30	40	70	80	90	100	140	180	220
Q	5x5x20	5x5x16	5x5x25	8x7x32	10x8x50	10x8x50	12x8x70	14x9x70	20x12x100
R	3	2	2	2	2	2	5	5	5
S 1	43	45	50	60	70	75	100	120	140
S 2	58	61	68	80	95	105	135	160	190
S 3	66	69	76	89	109	124	154	184	219
Ø T f7	62	72	92	122	152	182	222	262	352
Ø T5	50	-	100	115	130	-	200	260	310
Ø U	29	40	66	82	78	88,5	136	143	198
Ø V	35	35	60	70	100	125	140	195	240
Ø W	45	50	80	100	120	125	140	220	290
Z 1	15	16	18	20	25	30	35	40	50
Z 2	23	24	26	29	39	49	54	64	79
Z 3	29	34	39	44	54	64	74	84	109
Z 4	10	12	15	20	25	28	35	45	60
Z 5	27	-	28	33	40	-	54	63	73
Head I									
Ø a k6	18h9	15	20	30	40	50	80	95	130
b	20	24	29	39	49	54	79	99	119
c	37	44	49	59	69	74	99	119	139
Head II									
Ø d	65	72	92	122	150	182	222	262	352
Ø e	45	50	65	85	105	135	170	205	270
Ø f	4xØ 7	4xØ 9	4xØ 14	4xØ 17	4xØ 22	6xØ 26	8xØ 30	8xØ 33	8xØ 45
g	43	45	50	60	70	75	100	120	140
r	8	10	12	18	20	25	30	35	50
s	20	25	30	40	50	55	80	100	120
Ø x	18	30	35	50	65	85	115	140	185
Head III									
h	15	24	29	39	49	54	79	99	119
i	M 18x1,5	M 16x1,5	M 20x1,5	M 30x2	M 42x3	M 56x3	M 80x3	M 100x4	M 140x4
k	37	44	49	59	69	74	99	119	139
Head IV									
l - 0,2	20	25	30	40	60	75	100	120	160
m	50	60	70	100	130	150	230	300	360
n	30	40	50	70	100	120	160	200	280
Ø o H8	15	20	25	35	50	60	80	100	140
p	55	60	65	85	100	110	170	220	240
Ø u	30	40	50	65	90	110	140	170	220
v	15	20	25	35	50	60	80	100	140
v1	35	40	45	65	80	90	150	200	220

¹⁾ Size X.1 replaces previous size. The new sizes are compatible with the previous sizes. Previous sizes are available upon request.

²⁾ Size 32 will replace the existing size 31.

Screw jacks

3.7 HSE range dimension plans

3.7.1.2 With added-on limit switches Sm/Si

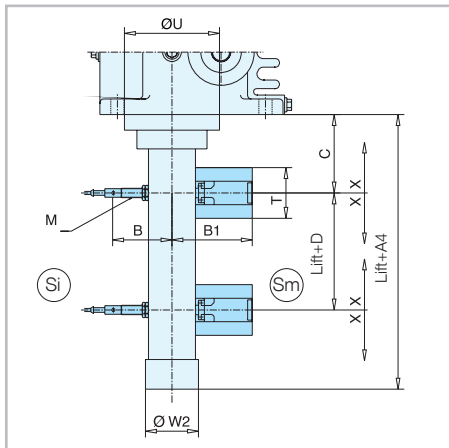

Size	A4	B	B1	C	D	T	M	ØU	ØW2	X
32	*on request									
36.1	140	86	*	70	12	*	12x1	72	42	±10
50.1	174	97	110	77	20	58	12x1	92	66	±10
63.1	180	106	110	88	25	58	12x1	122	82	±10
80.1	220	114	120	100	30	58	12x1	152	96	±10
100.1	*on request									
125.1	*on request									
140	*on request									
200.1	*on request									

3

3.7.1.3 Anti-turn device Vm/Vi with added-on limit switches

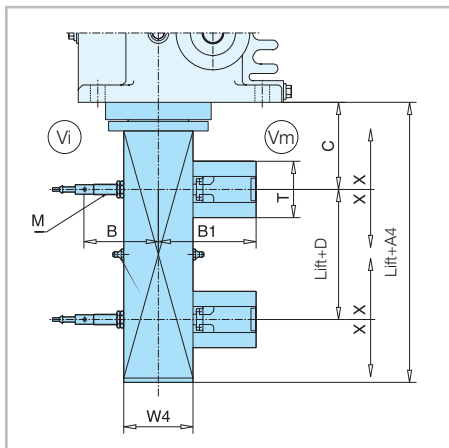

Size	A4	B	B1	C	D	T	M	W4	X
32	on request								
36.1	on request								
50.1	137	102	115	68	20	58	12x1	70x70	±10
63.1	150	107	115	75	25	58	12x1	80x80	±10
80.1	170	112	117	85	30	58	12x1	90x90	±10
100.1	on request								
125.1	on request								
140	on request								
200.1	on request								

3.7.1.4 With short safety nut

The short safety nut takes up the axial strain if the main nut breaks. This considerably increases the operating safety of the drive elements. The safety nut can also be used to precisely check for wear on the main nut, as the clearance between the two nuts changes according to the amount of wear. In the case of worm gear screw jacks with short safety nut, the direction of main stress (tensile and compression force) and the mounting position should be taken into account, as only a correctly fitted safety nut is capable of taking up the load.

Screw jacks

3.7 HSE range dimension plans

HSE type 1, compression force

Size	A	B	C	T ¹⁾	ØY	ØW
32	80	63	24	1	50	30
36.1	85	70	24	1	55	35
50.1	100	85	43,5	1,5	85	60
63.1	125	100	48,5	1,5	105	70
80.1	160	130	57	3	125	90
100.1	170	135	57	3	155	110
125.1	250	180	76	4	190	140
140	on request					
200.1	335	235	90	5	300	240

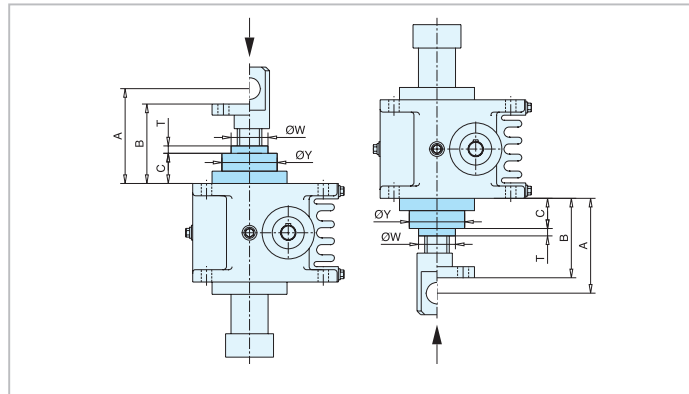

3

HSE type 1, tensile force

Size	A	B	T ¹⁾	ØU
32	lift + 67	25	1	47
36.1	lift + 67	25	1	56
50.1	lift + 77	35	1,5	80
63.1	lift + 82	40	1,5	92
80.1	lift + 102	60	3	107
100.1	lift + 102	60	3	132
125.1	lift + 122	80	4	158
140	on request			
200.1	lift + 137	95	5	272

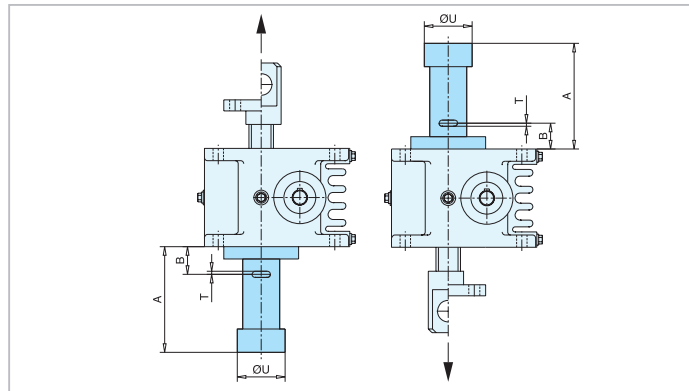

¹⁾ As new. If "T = 0", supporting and safety nut must be repaired.

3.7.1.5 With long safety nut (BGV C1 or VBG 14)

Worm gear screw jacks used on theatre stages (BGV-C1, former VBG 70), lifting platforms (VBG 14) or lifting systems that might affect personal safety are designed according to current regulations, and include such items as anti-drop systems (self-locking screws and/or mechanical safety brakes as part of the drive system). The function of the synchronizing device is guaranteed, if required, by additional components.



HSE type 1, compression and tensile force

Size	A	B	C
32	on request		
36.1	on request		
50.1	on request		
63.1	220	195	135
80.1	270	240	170
100.1	330	295	220
125.1	360	290	190
140	on request		
200.1	on request		

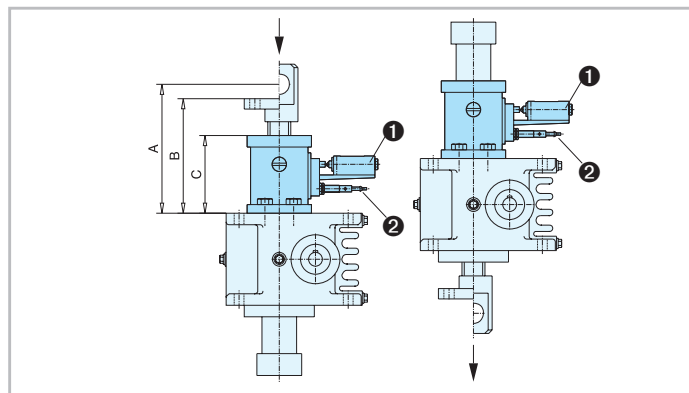

Ind. proximity switch ②	Mechanical limit switch ①
-------------------------	---------------------------

See chapter on accessories for technical data and dimension plans

Screw jacks

3.7 HSE range dimension plans



3.7.1.6 Swivelling configuration

In order to allow worm gear screw jacks to carry out swivelling and tipping movements, the drive elements must be secured at two points and permitted to move. This can be done using head IV on both screw ends or an articulated head.

3

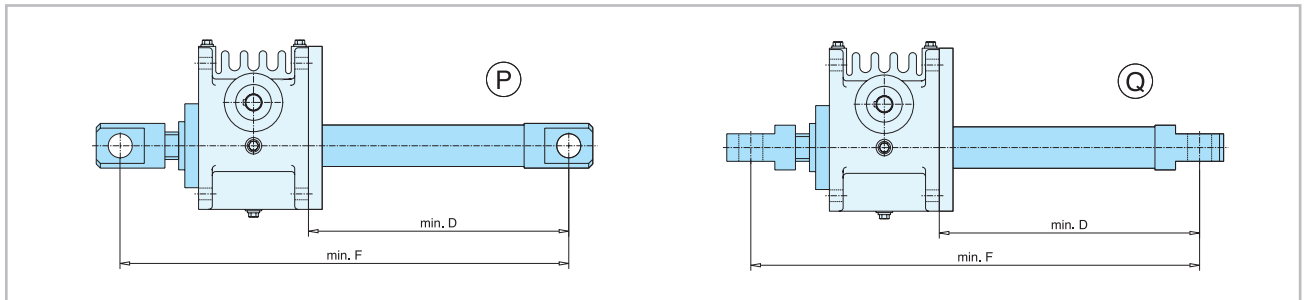

Size	D	F
32	on request	
36.1	lift +114	lift +303
50.1	lift +140	lift +361
63.1	lift +180	lift +454
80.1	lift +195	lift +534
100.1		
125.1	on request	
140		
200.1		

3.7.1.7 Swivelling configuration with added-on limit switches

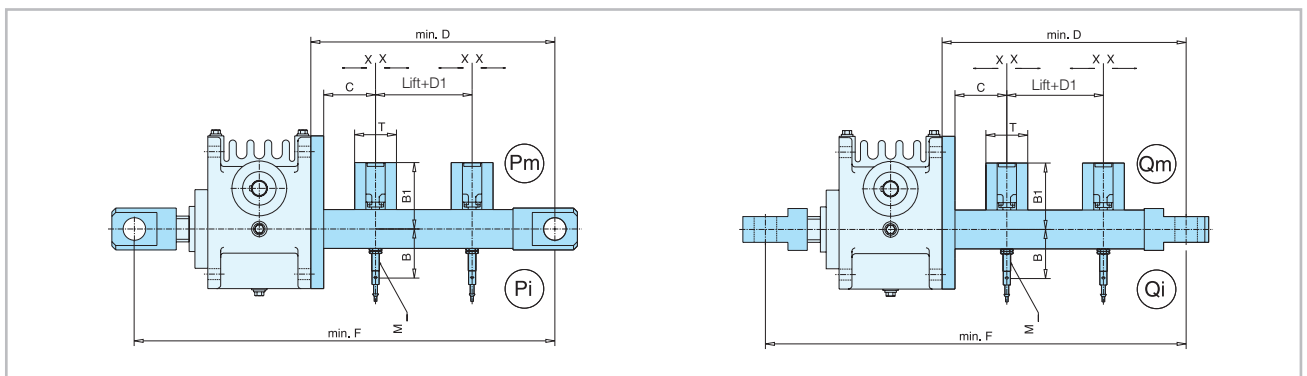

Size	B	B1	C	D	D1	F	M	T	X
32						on request			
36.1	86	93	50	155	12	344	12x1	58	± 10
50.1	97	105	50	175	20	396	12x1	58	± 10
63.1	106	110	50	205	25	479	12x1	58	± 10
80.1	114	120	50	250	40	589	12x1	58	± 10
100.1									
125.1									
140									
200.1									

Screw jacks

Application example



3



HSE high performance worm gear screw jack, type 1, special configuration for an elevation movement from 0 °C to 90 °C of an 11,1 m antenna.

Screw jacks

3.7 HSE range dimension plans

3.7.2 Type 2

3.7.2.1 Standard

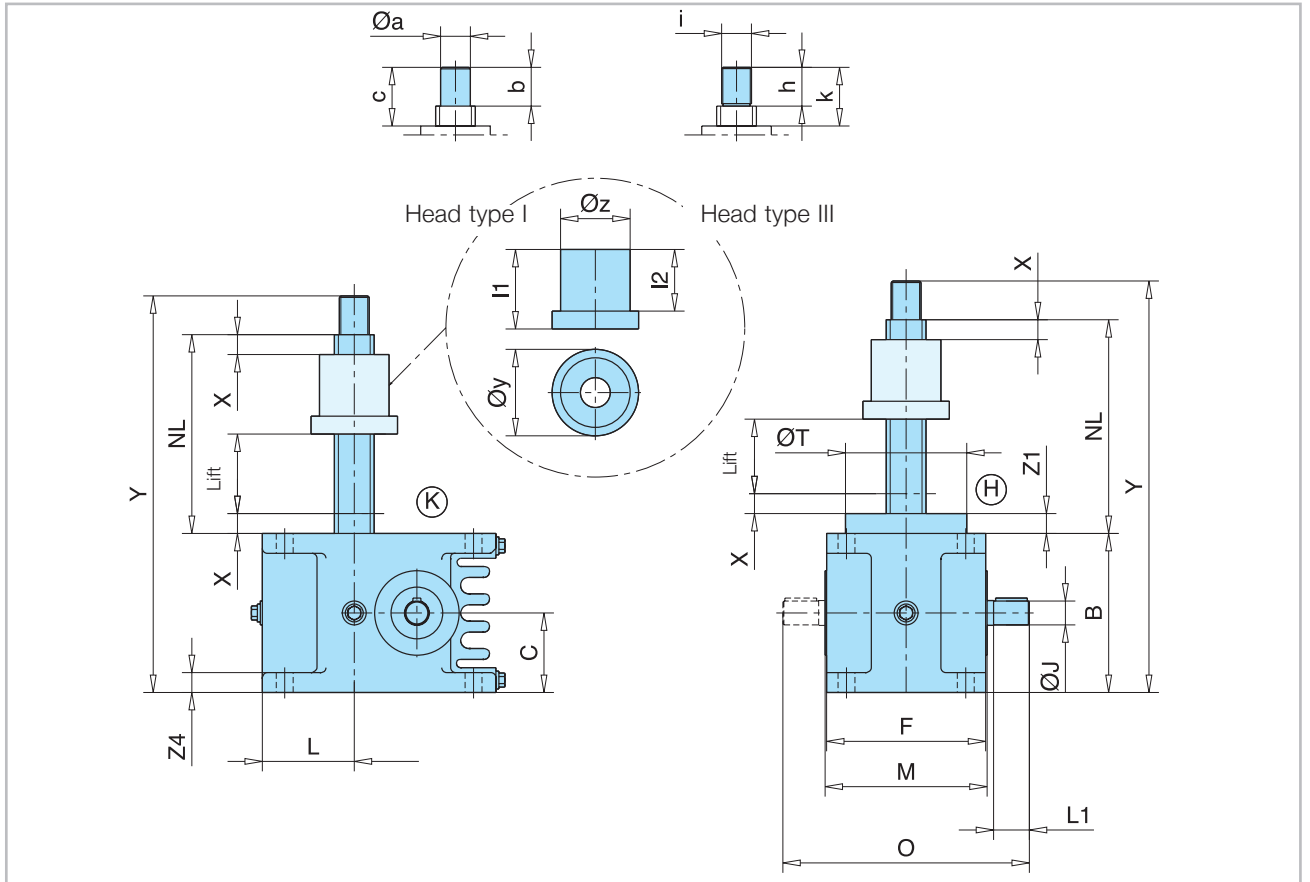

Missing dimensions - see type 1

Possible configurations:

K _____ Short cover

H _____ High cover

Screw jacks

3.7 HSE range dimension plans

Size	32	36.1	50.1	63.1	80.1	100.1	125.1	140	200.1
Screw	Tr 18x6	Tr 24x5	Tr 40x8	Tr 50x9	Tr 60x12	Tr 70x12	Tr100x16		Tr 160x20
B	80	105	130	160	200	230	300		450
C	40	52,5	65	80	100	115	150		225
F	80	105	130	160	200	230	300		460
ØJ k6	14	14	16	24	32	38	42		70
L	42	54	67,5	92,5	102,5	117,5	150		250
L1	15	18	28	36	58	58	82		105
M	83	108	133	163	204	235	305		470
NL config. „K“	lift + 85	lift + 95	lift + 120	lift + 140	lift + 170	lift + 170	lift + 200		lift + 260
NL config. „H“	lift + 100	lift + 111	lift + 138	lift + 160	lift + 195	lift + 200	lift + 235		lift + 310
O	140	140	192	238	322	356	474		682
Q	5x5x20	5x5x16	5x5x25	8x7x32	10x8x50	10x8x50	12x8x70		20x12x100
ØT	62	72	92	122	152	182	222		352
Safety X	20	20	20	20	20	20	20		20
Y	NL + 97	NL + 129	NL + 169	NL + 199	NL + 249	NL + 284	NL + 379	on request	NL + 569
Z1	15	16	18	20	25	30	35		50
Z4	10	12	15	20	25	28	35		60
Travelling nut									
l1	45	55	80	100	130	130	160		220
l2	35	43	62	78	105	100	115		140
Øy	50	65	87	105	110	120	190		260
Øz h9	40	45	70	80	90	90	150		200
Head I									
Ø a k6	10	15	30	40	40	50	80		130
b	20	24	39	49	49	54	79		119
c	37	44	59	69	69	74	99		139
Head III									
h	20	24	39	49	49	54	79		119
i	M 10	M 16x1,5	M 30x2	M 42x3	M 42x3	M 56x3	M 80x3		M 140x4
k	37	44	59	69	69	74	99		139

3

3.7.2.2 With short safety nut

The short safety nut takes up the axial strain if the main nut breaks. This considerably increases the operating safety of the drive elements. The safety nut can also be used to precisely check for wear on the main nut, as the clearance between the two nuts changes according to the amount of wear. In the case of worm gear screw jacks with short safety nut, the direction of main stress (tensile and compression force) and the mounting position should be taken into account, as only a correctly fitted safety nut is capable of taking up the load.



HSE type 2, compression and tensile force

Size	a ¹⁾	b	Øc	NL	
				config. K	config. H
32	5	25	40	lift+110	lift+125
36.1	10	35	45	lift+130	lift+146
50.1	10	50	70	lift+170	lift+188
63.1	10	60	80	lift+200	lift+220
80.1	10	60	90	lift+240	lift+265
100.1	10	70	90	lift+240	lift+270
125.1	15	95	150	lift+295	lift+330
140	on request				
200.1	15	115	200	lift+375	lift+425

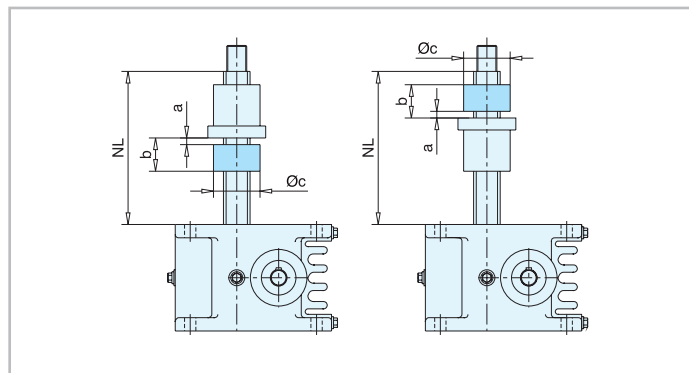

¹⁾ As new.

Screw jacks

3.7 HSE range dimension plans

3.7.2.3 With long safety nut (BGV C1 or VBG 14)



Worm gear screw jacks used on theatre stages (BGV C1, former VBG 70), lifting platforms (VBG 14) or lifting systems that might affect personal safety are designed according to current regulations, and include such items as anti-drop systems (self-locking screws and/or mechanical safety brakes as part of the drive system). The function of the synchronizing device is guaranteed, if required, by additional components.

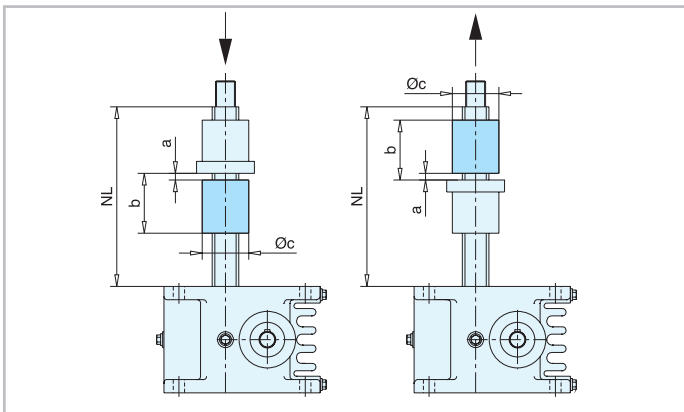

HSE type 2, compression and tensile force

Size	a ¹⁾	b	Øc	NL	
				config. K	config. H
32	5	50	40	lift+135	lift+150
36.1	10	65	45	lift+160	lift+176
50.1	10	90	70	lift+210	lift+228
63.1	10	110	80	lift+250	lift+270
80.1	10	140	90	lift+310	lift+335
100.1	10	140	90	lift+310	lift+340
125.1	15	175	150	lift+375	lift+410
140	on request				
200.1	15	235	200	lift+495	lift+545

¹⁾ As new. If "T = 0", supporting and safety nut must be repaired.

3

3.7.2.4 In HLA configuration



Ask for copie of our "HLA High Performance Linear Actuator" brochure!